

Submersible Mixer



Product description

Lambda Submersible mixers are mainly used for the purpose of mixing, agitating and making ring flows in the process of municipal and industrial sewage treatment and can also be used as a maintenance equipment for the landscape water environment through agitation. It can achieve the function of creating water flow, improving the quality of the water body, increasing the oxygen content in the water and effectively preventing the sedimentation of the suspended substances.

Lambda submersible mixers can also improve the growth rate of agriculture and promote higher quality of marine products. Recirculating systems can be created by this equipment designed especially for high water flow efficiency. It is a key equipment used in water treatment technology, can meet the technological requirement on the homogeneity of the two-phase solid-liquid and three-phase solid-liquid-gas flow and the fluidity in the bio-chemical processes in the flow path of the water treatment technology. The schematic drawing of the structure is shown as follows.

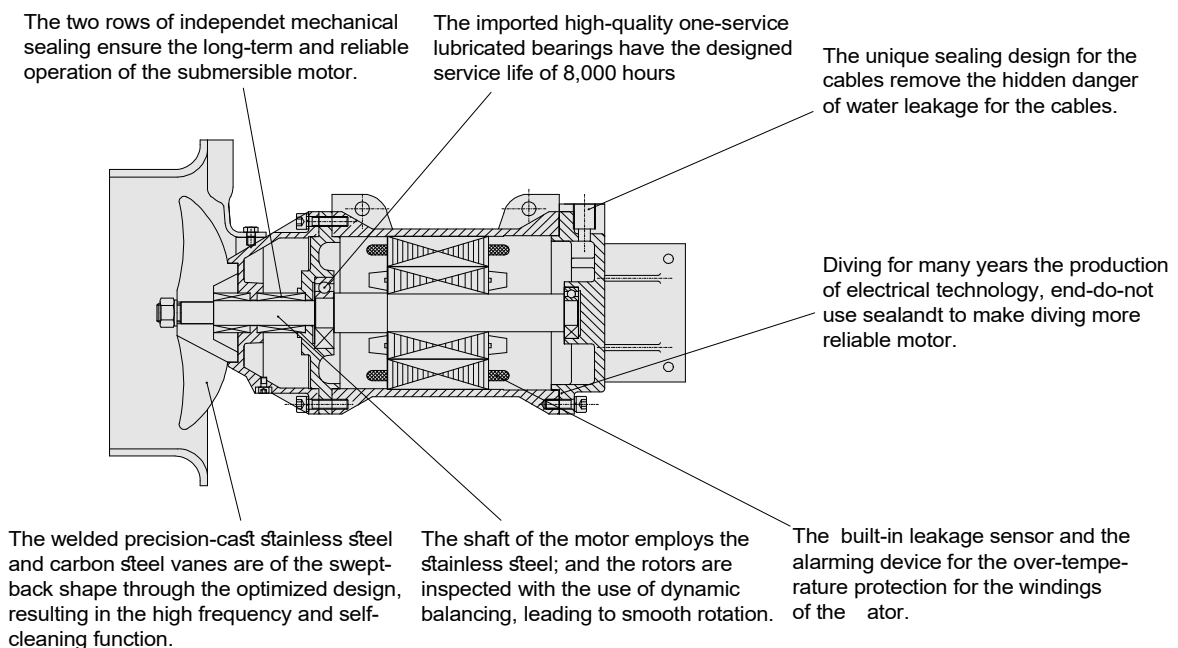

Specification

- Submersible mixer with frame and polyethylene float
 - Mixer : LSMF Series as per customers requirement
 - Float : PE with PU foam filled, float type PIN140A
 - Frame: approx. dimension 150cm(L) x 205cm(W) x 136cm(H)
- Submersible mixer with install guide system
 - Mixer : LSM Series as per customers requirement

Submersible Mixer

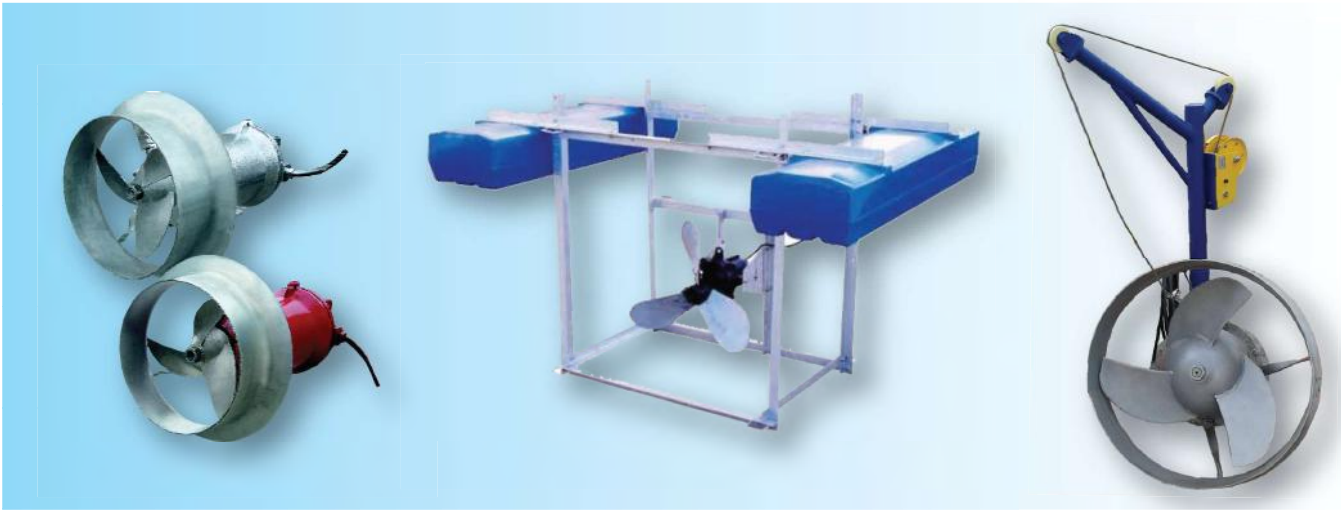

Information for Model Selection

The model selection of the submersible mixer is a rather complicated job. The correctness of the scheme selection will directly affect the normal usage of the equipment. The principle for the model is to enable the mixer to give full play to its mixing function in the appropriate volume. This standard can generally be determined with the use of the flow velocity. In line with the different technological requirement of the sewage treatment, the optimum flow velocity for the mixer model selection shall ensure the velocity range of 0.15~0.3m/s. In case of the flow velocity lower than 0.15m/s, the effect of agitation or mixing cannot be achieved. In case of the flow velocity more greater than 0.3m/s, the technological result will be affected and waste will be caused. Therefore, first of all, it is necessary to determine what kind of locations the mixer will be used in, for instance, sewage tank, slag pond or bio-chemical pond. Secondly, the parameters of the media such as content of the suspended substances, temperature, PH value as well as the shape of the pond, water depth and even the mode of installation and so on will all influence the model selection. Meanwhile, it is also necessary to consider the energy-saving factor, because this will affect the operation cost of the user in the future. Reference can be made to the diagrams of the flow field of the submersible mixer. For the purpose of obtaining the optimum mixing function under the different environments, we can supply a multiple of models of the submersible mixers to the users and provide the model selection service.

Diagrams of the Flow Field of Submersible Mixer

The flow velocity fields are located in the clear water with the boundary water flow velocity $V=0.1\text{m/s}$.

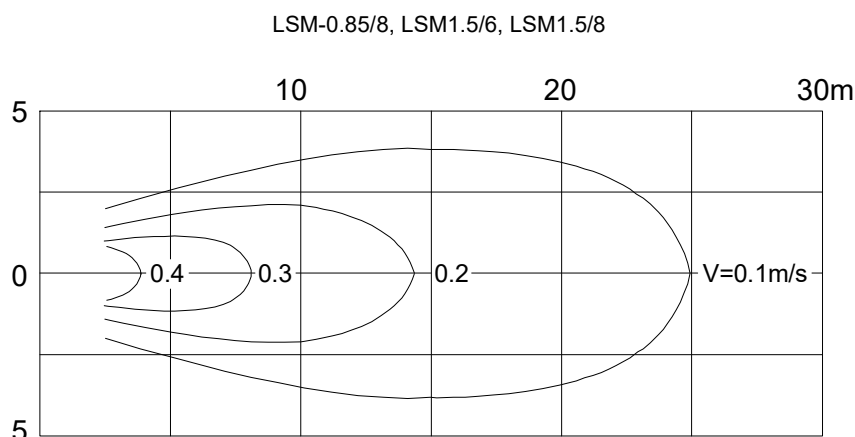

LSM-2.2/8, LSM4/6-320, LSM2.5/8, LSM3/8, LSM4/6-400

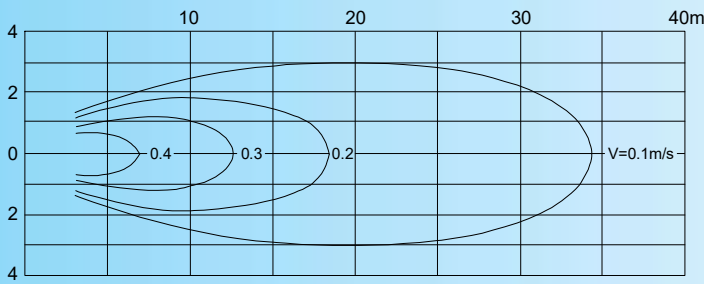

LSM-4/12, LSM5/12

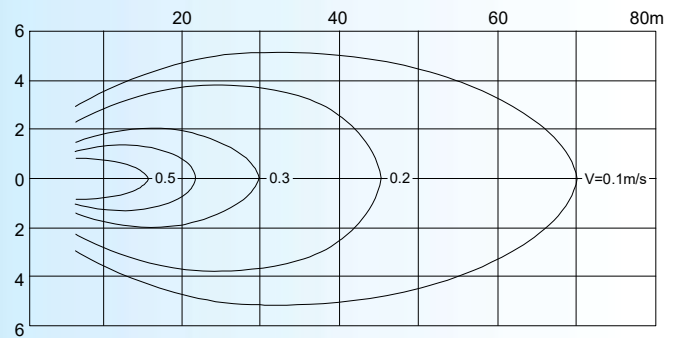

LSM-7.5/12, LSM10/12

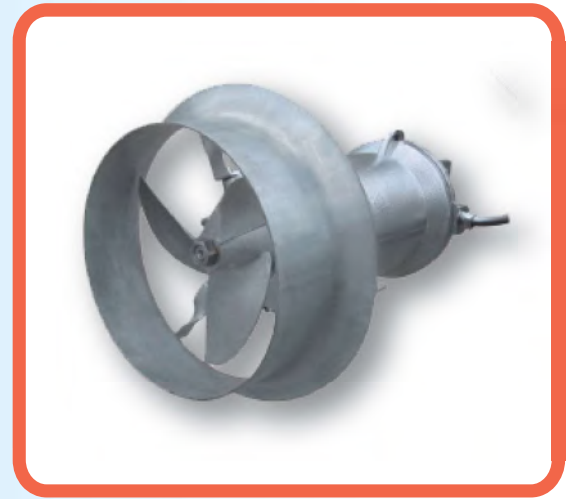
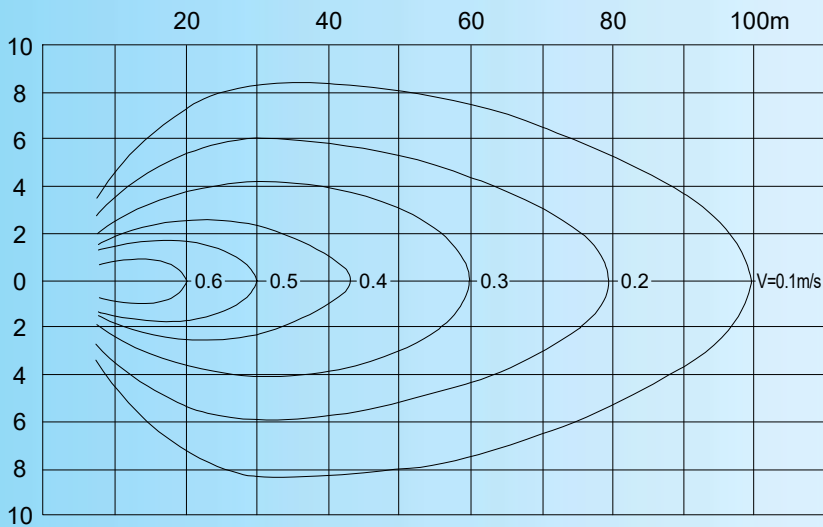

Installation Modes and Dimensions

The submersible mixers can be installed in a multiple of modes. Here are four generally accepted modes of installation for selection with reference made to the following table.

Model	a	D	b	L	h1min	h2min	Installation System
LSM-0.85	Ø48	360	330	630	500	110	I-1, I-2
LSM-1.5/6	Ø48	360	330	630	500	110	I-1, I-2
LSM-2.2/8	Ø70	460	320	970	800	150	II
LSM-4/6	Ø70	460	320	970	800	150	II
LSM-1.5/8	Ø70	530	320	960	500	200	II
LSM-2.5/8	Ø70	530	320	960	500	200	II
LSM-3/8	Ø70	530	320	1010	800	200	II
LSM-4/6	Ø70	530	320	1010	800	300	II
LSM-4/12	Ø100	820	335	1150	1100	300	III
LSM-5/12	Ø100	620	335	1150	1100	300	III
LSM-7.5/12	Ø100	820	335	1280	1500	300	III
LSM-10/12	Ø100	820	335	1280	1500	300	III

Installation System

System I - 1

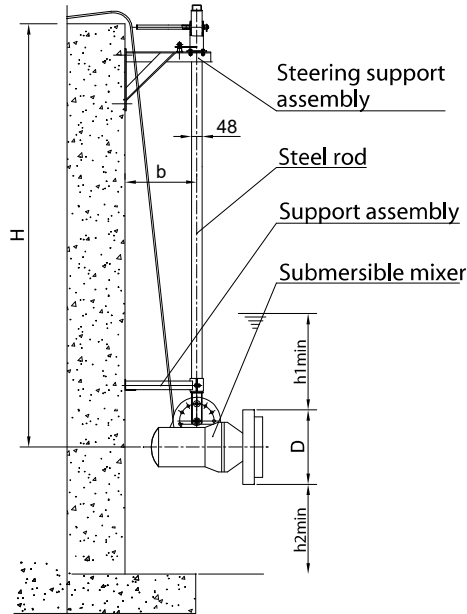

System I -- 2

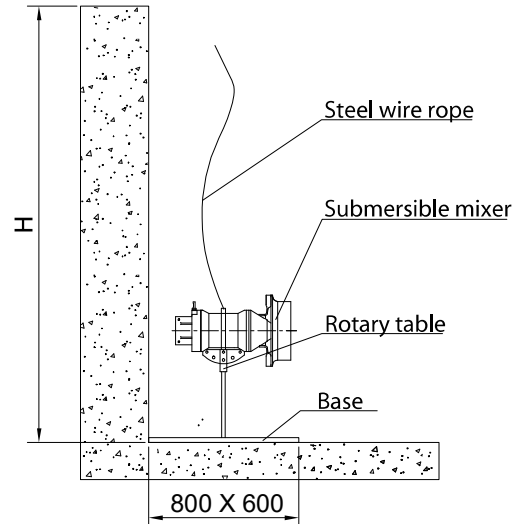

System II

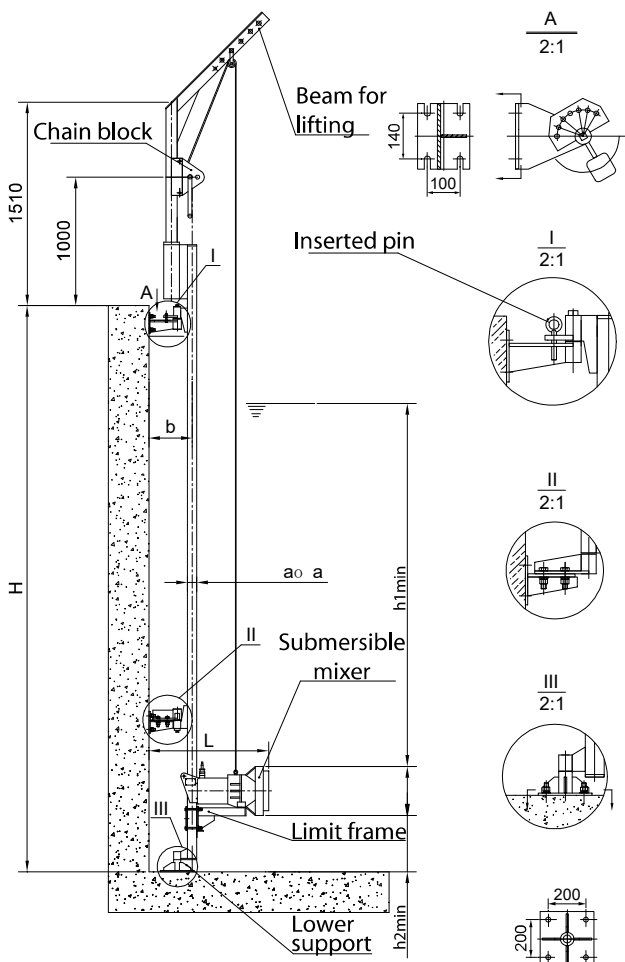

System III

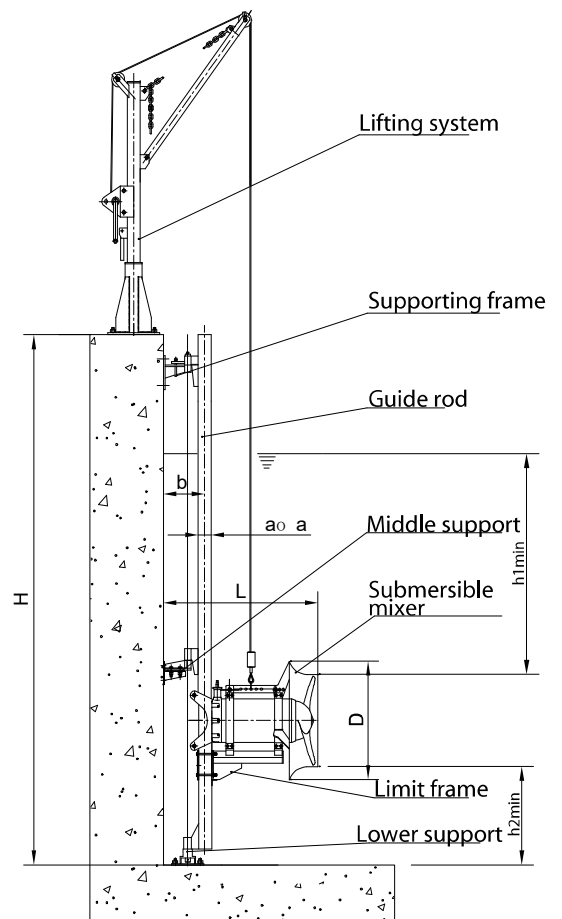

Installation System

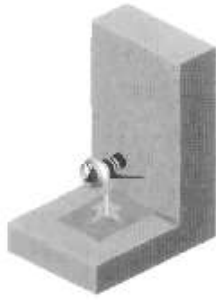

NOTE:

1. The special installation systems for the submersible mixer can facilitate the quick installation and dismantling of the submersible mixer under the conditions of no need for draining off sewage from the pond.
2. Installation System I-1 is only suitable for the pond depth $<4\text{m}$ and the mixer models of LSM0.85/8 and LSM1.5/6 and with possibility of adjusting the angles in both the horizontal and longitudinal directions. With the depth $>4\text{m}$, the installation system I-2 shall be chosen.
3. For Installation System II and III, the guide rod can rotate round the axial line of the guide along the horizontal direction with the maximum angle of rotation $\pm 6^\circ$.
4. With $H > 4\text{m}$, it is necessary to add a supporting frame between the guide rods.
5. The supporting frame and the lower support shall be fixed onto the pond and the pond bottom with the use of the expansion bolts or chemical anchors; any pre-prepared holes can be dispersed with.
6. While placing an order by customer, please supply the pond depth H and the drawing of the pond shape so as to determine the dimensions of the guide rod and the number of the support frames.
7. The installation systems may empty the material of the stainless steel or carbon steel for the selection of the corrosion resisting properties.
8. A multiple of mixers can share on lifting system.

Operating modes

The installation and positioning of the submersible mixers will produce a great impact on the effect of mixing. In order to obtain the double operating result with the half effort, it is suggested that the advice of the specialized designers shall be followed and full consideration given to the shape of the pond, position of the water inlet and outlet, the vortex resulting from the outflow from the mixer onto the structures and some other conditions. Every effort shall be made to reduce the short-circuit circulation and the occurrence of dead corners and avoid the dashing of the flow against the pond wall for lowering the flow velocity. Making reference to the diagrams of operating-modes below will help you to make a reasonable selection of the mixers and their installation modes.

Mixing and agitating series

